

VICTORY ENERGY[®]

COMPANY ENGINEERING MANUFACTURING PRODUCTS AFTERMARKET CAREERS NEWS CONTACT

ENHANCED HEAT RECOVERY



EXPLORER[®]
series

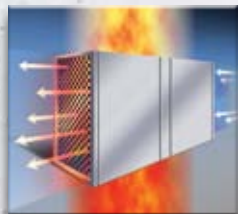

Concept to Completion



HEAT RECOVERY...

Start Saving today

Victory Energy offers heat recovery solutions for all your heat recovery needs. An Explorer® economizer from Victory Energy can “economize” your fuel usage by recovering energy that would otherwise be wasted. An Explorer® economizer from Victory Energy can immediately reduce your fuel costs and carbon foot-print.

Beyond Boiler-Plate

Victory Energy's heat recovery solutions are custom engineered, for your application, by our industry leading thermal design experts to maximize heat recovery. We provide solutions for gas-liquid, gas-gas as well as liquid-liquid heat transfer applications.

Every aspect of the design is chosen with the goal of providing a product that will perform trouble-free for many years. From selecting the right metallurgy for the application to the right enhanced surface and tube layout, based on fuel and fouling concerns, paying close attention to erosion, corrosion and vibration concerns, you can be rest assured that our heat recovery unit will be ideally suited for your application.

No application is too small or too big for us. We thrive on an atmosphere of innovative thinking and breakthrough methodology. We carry this attitude forward as we work closely with our fabrication personnel and field technicians. In addition to providing innovative solutions, we are constantly looking for ways to improve renewable energy technologies and maximize waste heat recovery processes.

Victory Energy offers a complete suite of heat recovery products and accessories for all your applications, including:

- **Boiler Feedwater Economizers**
 - Rectangular
 - Cylindrical
- **Condensing Economizers**
- **Waste Heat Oil Heaters**
- **Tubular Air Pre-heaters**
- **Liquid-Liquid heat exchangers**
- **Transitions, Stack, Support Steel, Controls, etc.**

Rectangular Economizer



Engineered to order for your specific application, our rectangular Explorer Economizer Series can be designed for boiler sizes ranging from 100 BHP to greater than 500,000 lb/hr of steam flow. We also can offer field assembled economizers for utility sized boilers. The rectangular economizer uses high frequency resistance welded finned tubes to recover heat from the flue gas that flows counter-current to the boiler feedwater. Victory Energy economizers can be designed to recover energy from clean burning fuels like natural gas to fouling fuels such as oil, coal or wood. Our economizers are designed for economically optimum heat recovery with typical paybacks being in months, not years. Insulated and lagged with a gas tight casing, our economizers will be structurally engineered to handle any loads transmitted through your duct work, stack, and structural steel accessory components.

Cylindrical Economizer

Suitable for boilers ranging from 50 BHP to 100,000 PPH, our cylindrical economizers are ideal for firetube boilers as well as watertube boilers.

Cylindrical economizers can be mated directly to the round stack for ease of installation. Available in either carbon steel or stainless steel construction, the cylindrical Explorer Economizer Series can even be installed for horizontal gas flow.



RECOVERED HEAT = LESS FUEL & EMISSIONS!

Think Condensing

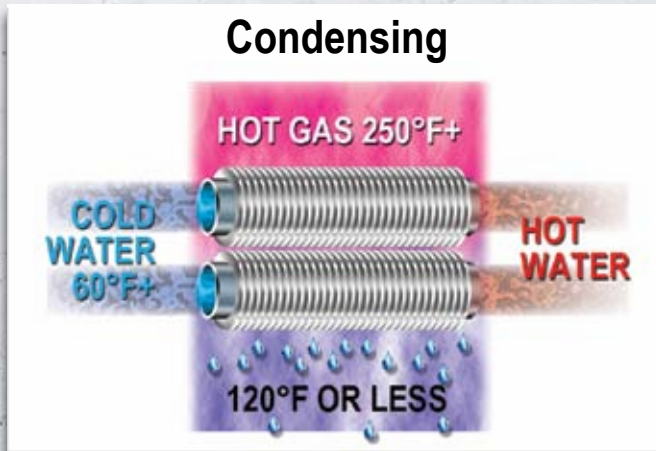

It is important to note that the majority of the heat content (of the exhaust flue gas), is “trapped” in the moisture in the flue gas. Flue gas from natural combustion has approximately 11% by weight of moisture. Each pound of moisture, if condensed, can release 1,000 btu’s of energy: By condensing this moisture, the amount of energy that can be recovered in an economizer can be significantly increased. Condensing needs feedwater at temperatures below the water dew-point. Let us evaluate your application to see if a condensing economizer is suitable for you. The cold sink may be either make-up water or a completely separate stream to be used elsewhere. Boiler efficiencies reaching 95% may be obtained by adding a condensing economizer to your system. Victory Energy can also provide a two-stage economizer with one stage (coil) transferring sensible heat to de-aerated feed-water and another coil transferring the latent heat to make-up / cold water. Both coils will be in a common housing and can even be designed for vertical gas flow up.

Air Pre-heaters



Victory Energy can design, engineer and manufacture tubular air preheaters, typically used for combustion air pre-heating. Rigorously engineered, our air pre-heaters are custom designed for your plant layout. We can handle very high flue gas temperatures, up to 1,750° F with our refractory lined units.

Waste Heat Recovery Units

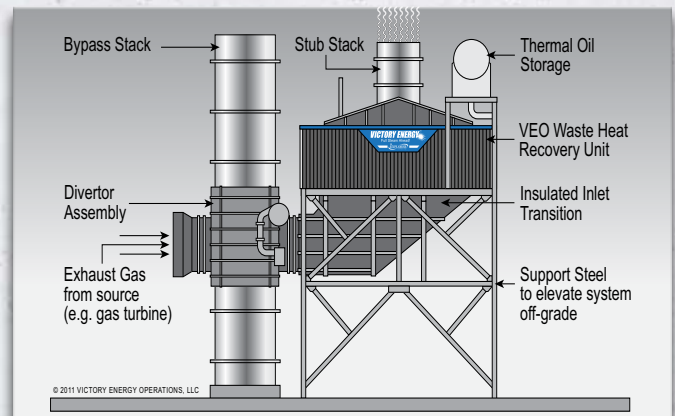

Victory Energy can design heat recovery units for non-boiler related applications. Waste heat can be recovered from various sources, for example, gas turbines, cement kilns, diesel generators, to name a few, to heat either a glycol-water mixture or thermal oil. Recovered heat can be used for a variety of applications including on-site power generation. Our heat recovery units can handle inlet gas temperatures of up to 2,000° F.

Decrease Fuel Usage

65,000 lb/hr boiler with 7,200 hours of annual operation.
Natural gas cost of \$4.50 / Mscf.

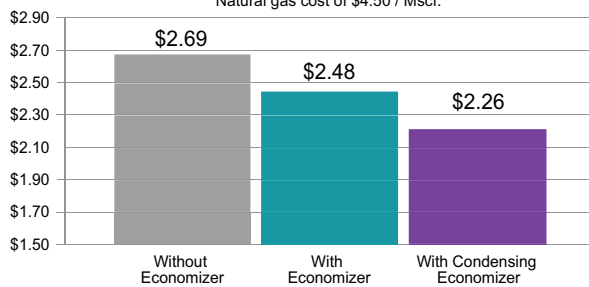

MM \$/year of fuel usage.



QUALITY FEATURES = LONG SERVICE LIFE!

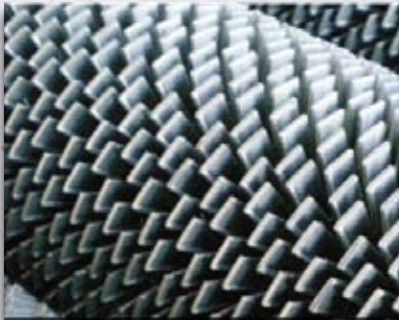

● ● Serrated fins on a staggered tube layout are best suited for clean fuels.



● ● Solid fins on an inline tube layout are best suited for dirty fuels.



Minimum wall thickness far exceeds ASME requirements.

Rigorously engineered for your application.

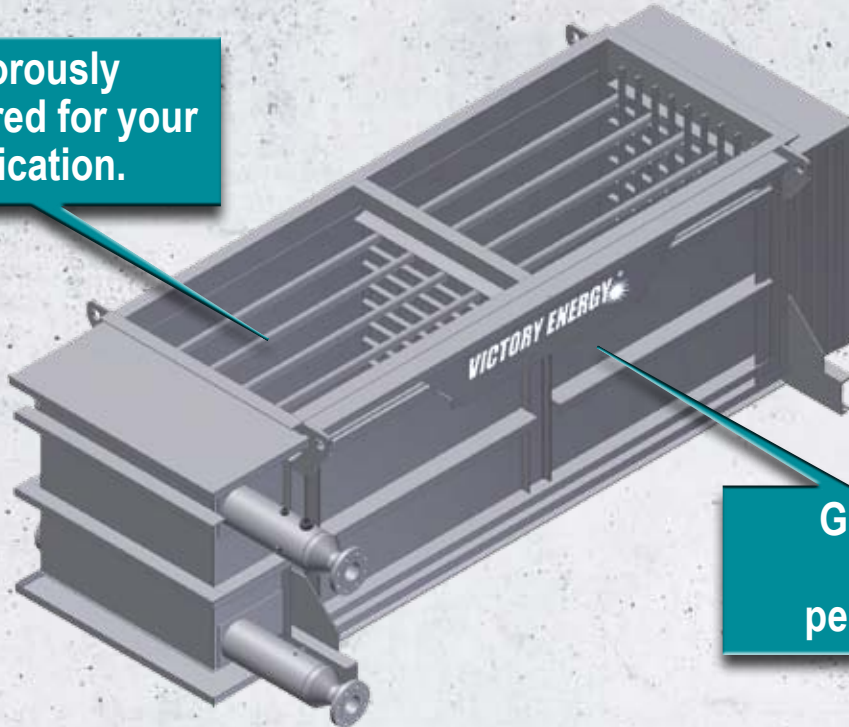

Guaranteed thermal performance.



Full-time (24/7) service, installation and start-up.



All units are shrink-wrapped for shipping.



State-of-the-art manufacturing facilities.



RECOVERED HEAT TRANSLATES TO RESOURCES SAVED!

Ancillary Equipment

Victory Energy can provide a complete suite of ancillary equipment to maximize the value of our products.

- Duct-work
- Transitions including D-type transitions
- Support steel to elevate units off-grade
- Stack
- Controls
- Dampers
- Expansion joints

Heat Recovery Products are a vital part of our sustainability initiative and a part of the many ways in which we provide innovative solutions to maximize waste heat recovery.



Our commitment to the 212 Principle continues to drive our dedication to customer satisfaction.

The **212** Principle

At 211 degrees, water is hot. At 212 degrees, it boils. And with boiling water, comes steam. And with steam, we power the progress of change.

The power of one extra degree!



VICTORY ENERGY®

FOLLOW A LEADER



www.victoryenergy.com

1-877-783-2665

VICTORY ENERGY OPERATIONS, LLC | 10701 E. 126TH ST. N., COLLINSVILLE, OK 74021 | TEL: 918.274.0023 FAX: 918.382.4896

Concept to Completion

